

AKABA

AIA

DESIGN ISAAC PIÑEIRO

Inspired by the Japanese sense of simplicity and harmony, AIA is designed to offer a connection between the human habitat and the natural world. Soft, clean, sensuous curves create a form that affords extraordinary refinement.

To enhance the already elegant design the chair comes in natural wood or a wide range of fabrics when the use of upholstery is merited. The painted steel frame in conjunction with wood or upholstery offers versatility in its application. Where minimal sensibilities are needed in residential, hospitality and commercial settings, this chair works beautifully.



AIA

DESIGN IRATZOKI LIZASO

AKABA

DESCRIPTION

Chair without arms. Steel tube frame powder coated or gloss smooth. Seat and back in varnished plywood. Option with only seat upholstered or seat and back upholstered.



DIMENSIONS

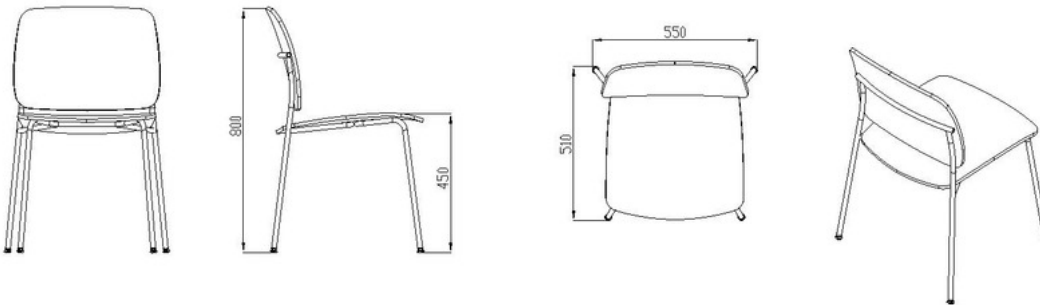

FINISHES

METAL



FABRICS

Camira, Spradling, Gabriel, Kvadrat or leather.



WOOD

Oak veneer



+

WARRANTY



CERTIFICATES AND AWARDS

UNE-EN 16139:2013

Furniture - Strength, durability and safety - Requirements for non-domestic seating



AKABA
National
Design
Award 2000



AKABA "Principe Felipe" Award to
the Business Excellence 2002



ISO 9001



ISO 14001



ISO 14006